

#### Pull Cable

Pull Cable for Brake Calipers DV 020 FKM and DH 020 FKM as well as DV 020 MKM and DH 020 MKM are available in variable cable lengths.

Cable ends are designed for attachment to Brake Calipers or Hand Brake Lever B 50452.

#### Features

- Slide ease
- Inner member stainless steel wrap
- Suitable for small bending radii
- Steel elements galvanized
- Stainless steel drawbar

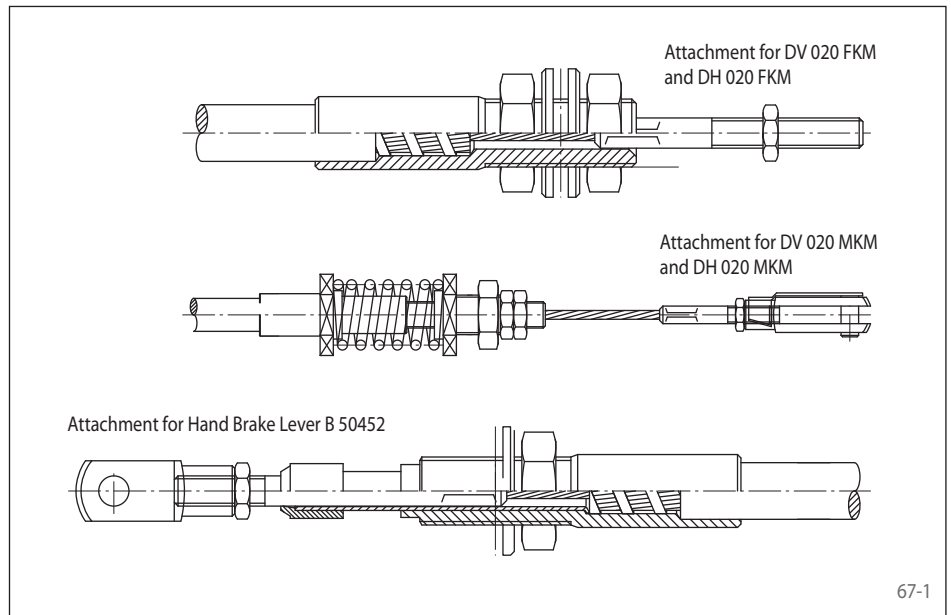

#### Hand Brake Lever B 50452

The Hand Brake Lever B 50452 is used to operate Brake Calipers DV 020 FKM and DH 020 FKM as well as DV 020 MKM and DH 020 MKM.

Article Number: 4561.000.001.R50452

#### Features

- Two positions: "open" or "closed"
- Over center locking
- Brake pad wear compensation
- Attachment for pull cables
- Optional with electric switch available

